



(19) **United States**

(12) **Patent Application Publication**  
**Baltazar-Lopez et al.**

(10) **Pub. No.: US 2011/0227395 A1**

(43) **Pub. Date: Sep. 22, 2011**

(54) **METHOD OF AND APPARATUS FOR PLASMA BLASTING**

(52) **U.S. Cl. .... 299/14; 299/20**

(57) **ABSTRACT**

(75) **Inventors: Martin E. Baltazar-Lopez,**  
Auburn, AL (US); **Steve R. Best,**  
Montgomery, AL (US)

A method, system and apparatus for plasma blasting comprises a solid object having a borehole, a blast probe comprising a high voltage electrode and a ground electrode separated by a dielectric separator, wherein the high voltage electrode and the dielectric separator constitute an adjustable probe tip, and an adjustment unit coupled to the adjustable probe tip, wherein the adjustment unit is configured to selectively extend or retract the adjustable probe tip relative to the ground electrode and a blasting media, wherein at least a portion of the high voltage electrode and the ground electrode are submerged in the blast media. The blasting media comprises a thixotropic or electro-rheological fluid. The adjustable tip permits fine-tuning of the blast. The property of instantaneous high viscosity of thixotropic and electro-rheological fluids is advantageously used to seal the cavity containing the blasting probe thereby increasing the blasting pressure making the whole system more efficient.

(73) **Assignee: AUBURN UNIVERSITY,** Auburn, AL (US)

(21) **Appl. No.: 12/726,038**

(22) **Filed: Mar. 17, 2010**

**Publication Classification**

(51) **Int. Cl.**  
**E21C 37/14** (2006.01)  
**E21C 37/18** (2006.01)

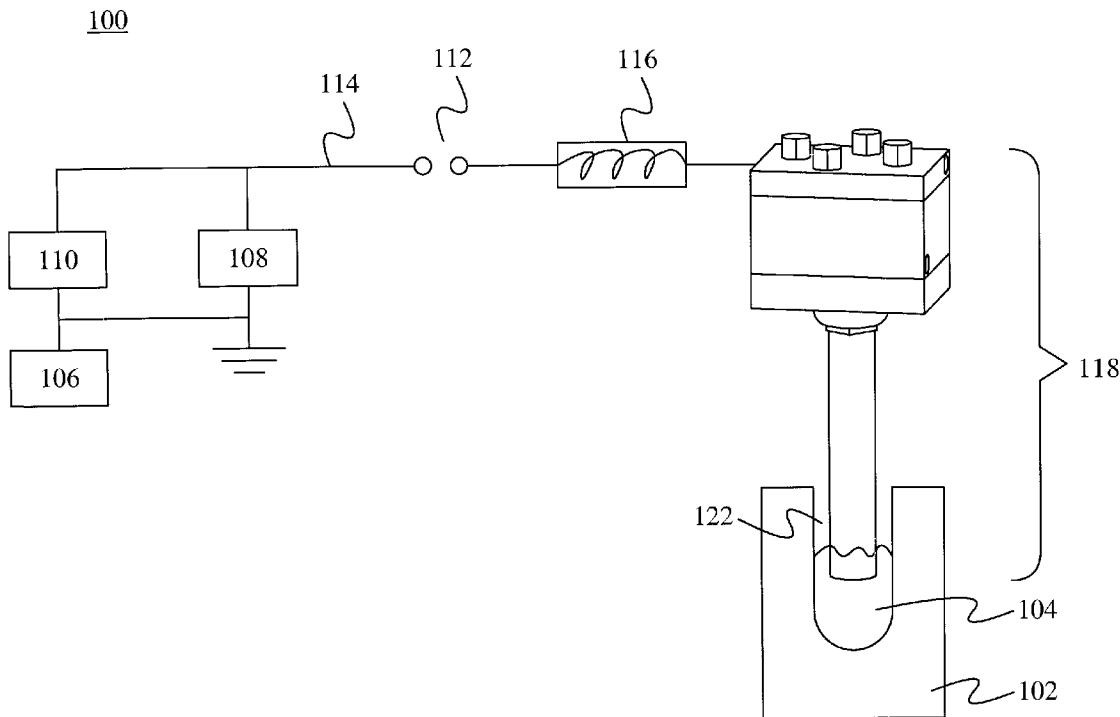

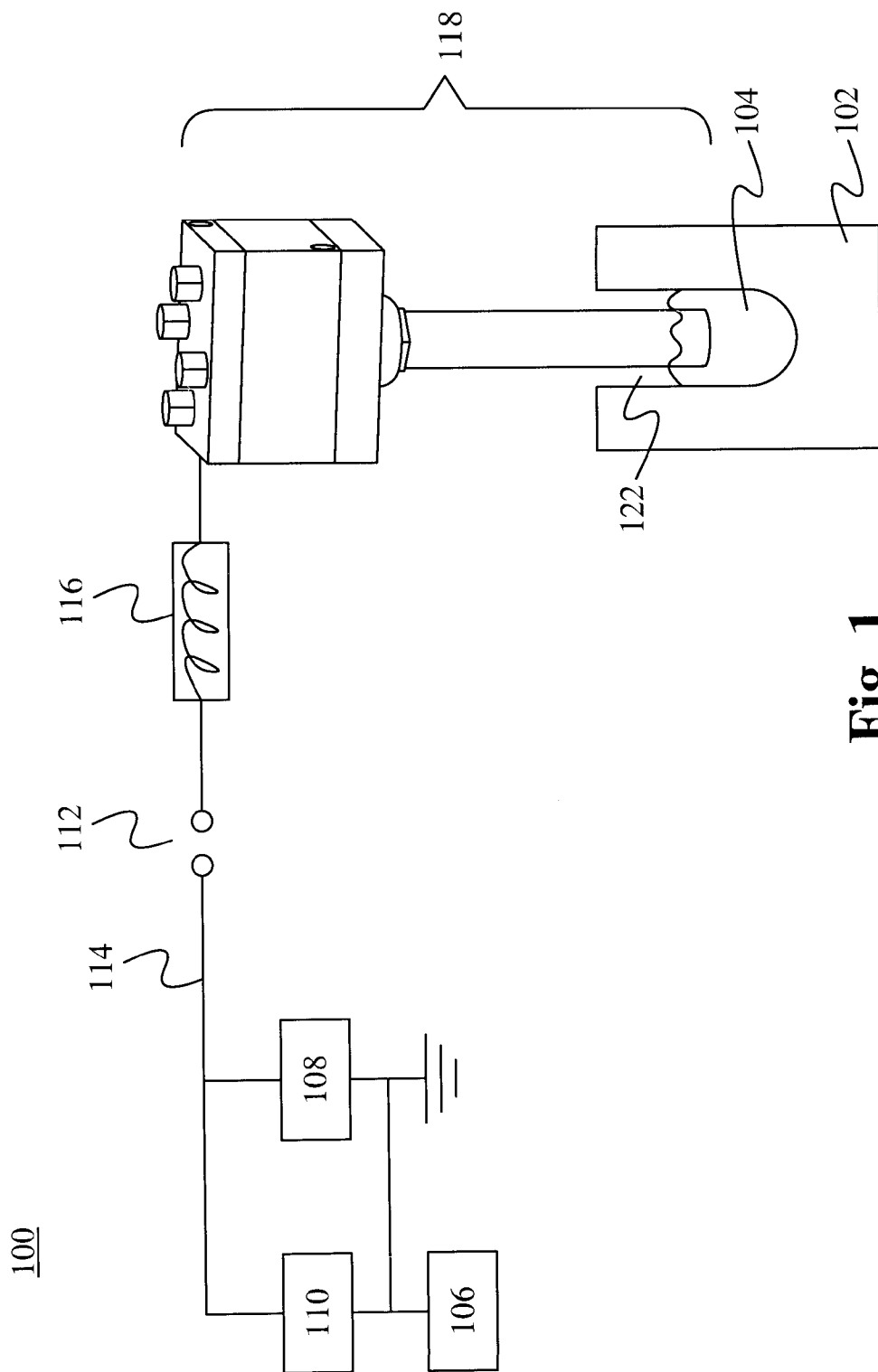

Fig. 1

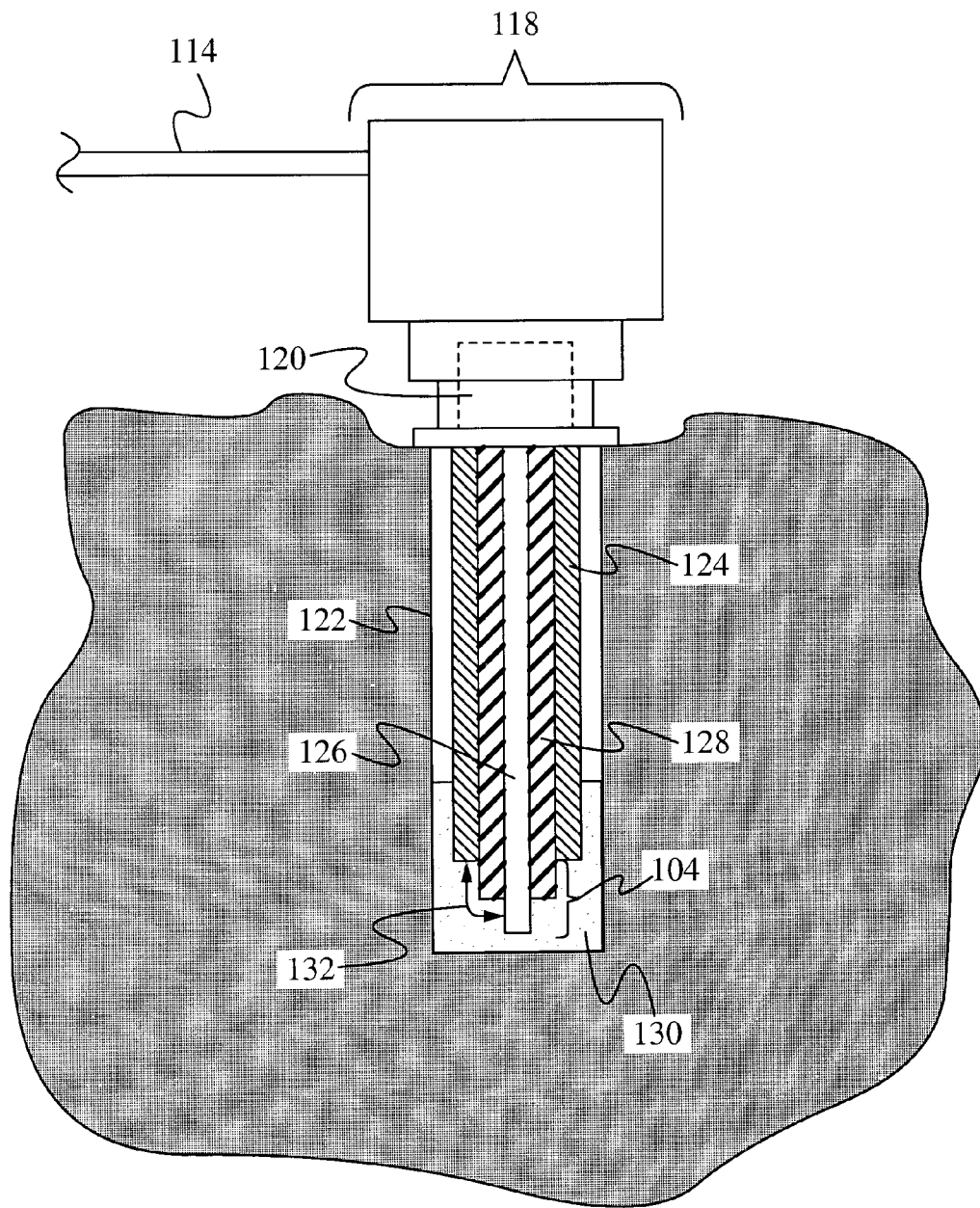
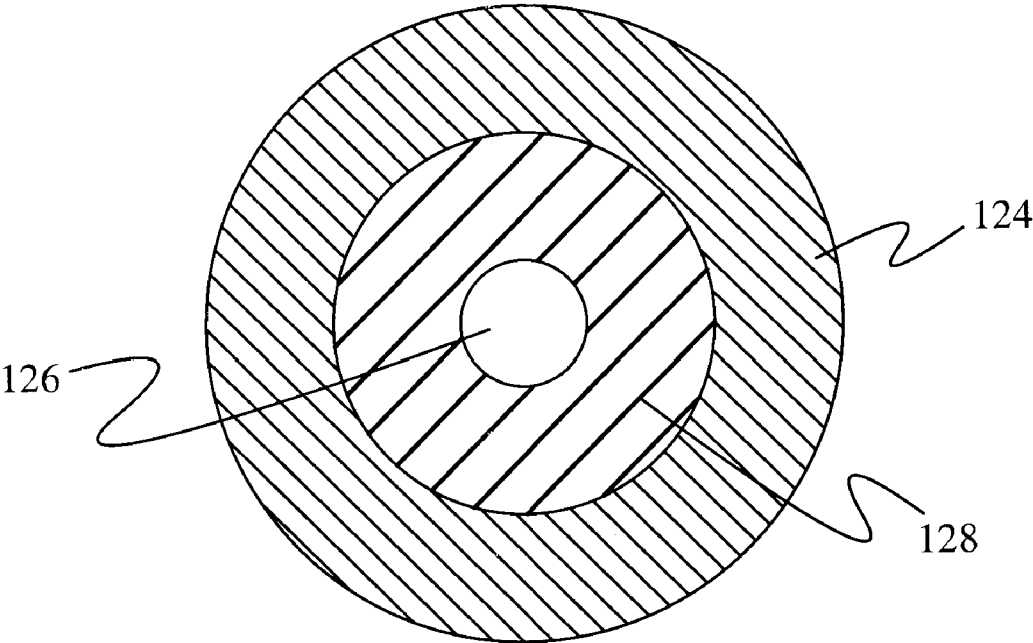
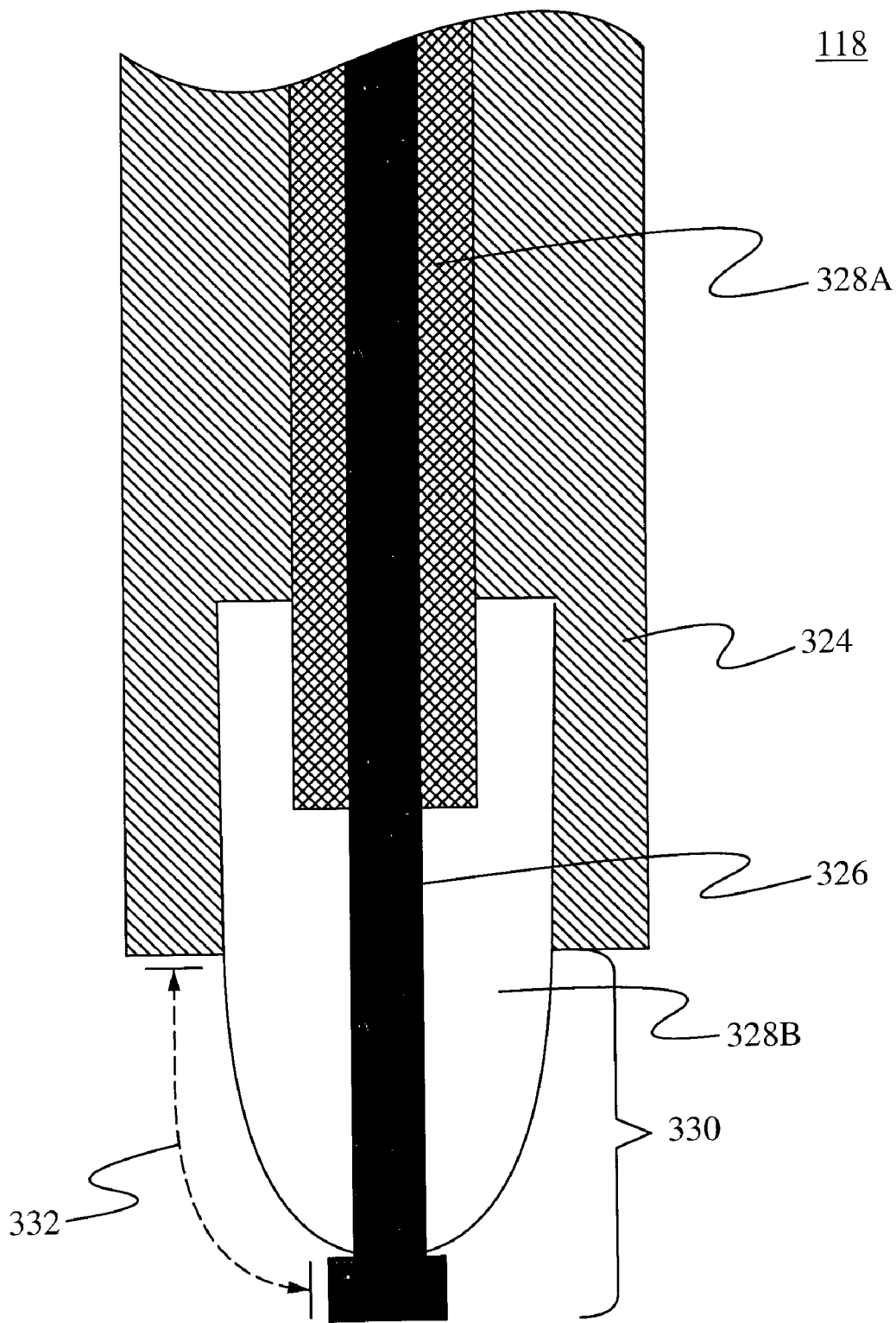

Fig. 2A

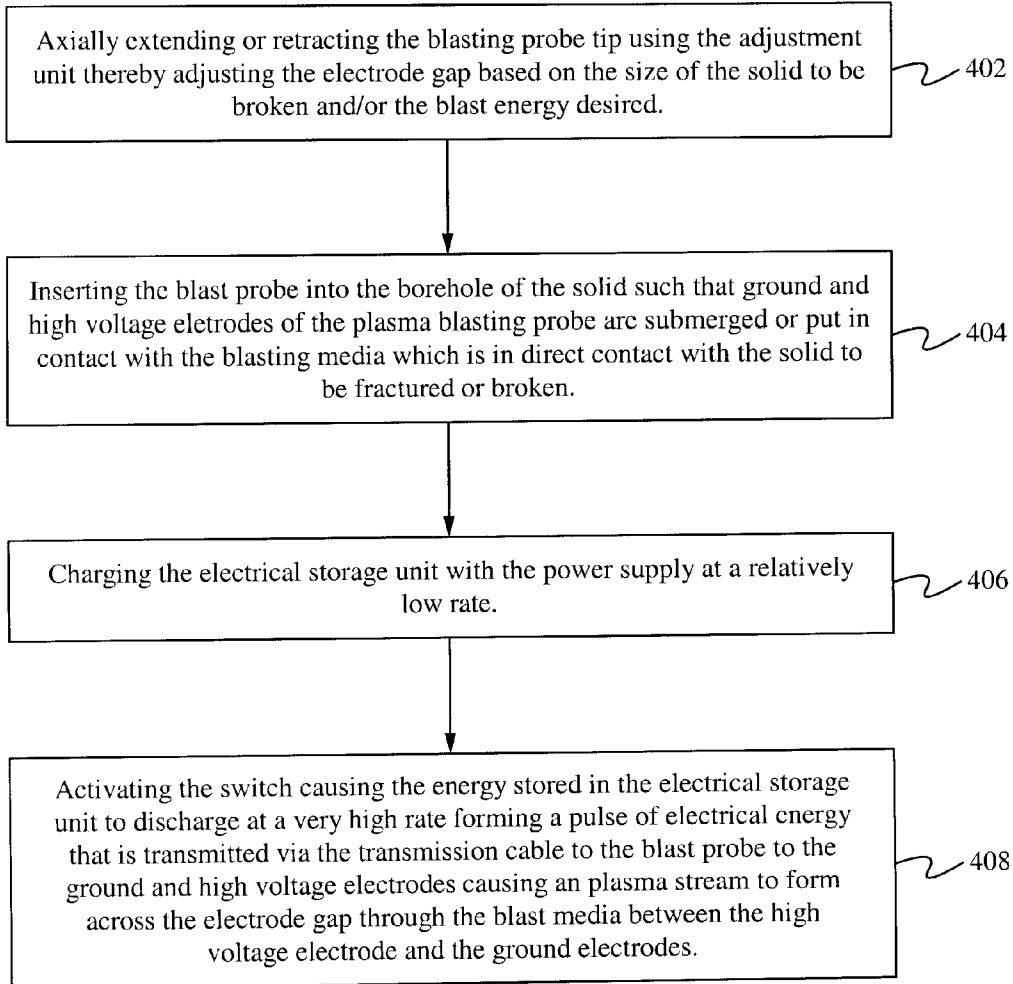

**Fig. 2B**



**Fig. 3**

400



**Fig. 4**

## METHOD OF AND APPARATUS FOR PLASMA BLASTING

### STATEMENT REGARDING FEDERALLY SPONSORED RESEARCH

[0001] The invention was made in the course of work supported by grant No. 07-060287 from the National Aeronautics and Space Association. The United States government has certain rights in this invention.

### FIELD OF THE INVENTION

[0002] The present invention relates to the field of improved plasma blasting. More specifically, the present invention relates to the field of a reusable plasma blasting probe with adjustable probe tip for use with thixotropic fluids as an electrolyte media.

### BACKGROUND OF THE INVENTION

[0003] The field of surface processing for the excavation of hard rock generally comprises conventional drilling and blasting. Specifically, whether for mining or civil construction, the excavation process generally includes mechanical fracturing and crushing as the primary mechanism for pulverizing/excavating rock. Many of these techniques incorporate the use of chemical explosives. However, these techniques, while being able to excavate the hardest rocks at acceptable efficiencies, are unavailable in many situations where the use of such explosives is prohibited due to safety, vibration, and/or pollution concerns.

[0004] An alternate method of surface processing for the excavation of hard rock incorporates the use of electrically powered plasma blasting. In this method, a capacitor bank is charged over a relatively long period of time at a low current, and then discharged in a very short pulse at a very high current into a blasting probe comprised of two or more electrodes immersed in a fluid media. The fluid media is in direct contact with the solid substance or sample to be fractured. These plasma blasting methods however, have been historically expensive due to their inefficiency.

### SUMMARY OF THE INVENTION

[0005] A plasma blasting system for breaking or fracturing solids such as rocks comprises a blasting probe. The blasting probe comprises an adjustment unit, a high voltage electrode, a ground electrode and a dielectric separator. The dielectric separator and the high voltage electrode constitute a probe tip that is coupled to the adjustment unit such that the adjustment unit is able to extend and retract the adjustable tip with respect to the ground electrode. In this manner, the blasting system is able to precisely control the electrode gap and correspondingly the blast power of the system creating a more efficient blasting system. Further, the system comprises a blast media such as a thixotropic fluid that enhances the power of the blasting system relative to the power input into the system by not allowing the blast shock wave cause by the input energy to easily dissipate. Thus, the conversion of input energy to output energy is made more efficient again improving the overall efficiency of the plasma blasting system.

[0006] In one aspect the present application relates to a blasting system. The blasting system comprises a solid object having a borehole, a blast probe having a high voltage electrode and a ground electrode, wherein the blast probe is positioned within the borehole and a blast media comprising

a thixotropic fluid, wherein at least a portion of the high voltage electrode and the ground electrode are submerged in the thixotropic fluid. In some embodiments, the high voltage electrode and the ground electrode are separated by a dielectric separator wherein the high voltage electrode and the dielectric separator constitute an adjustable probe tip. In some embodiments, the blast probe further comprises an adjustment unit coupled to the adjustable probe tip and configured to extend and retract the blast probe tip relative to the end of the ground electrode. Alternatively, the high voltage electrode and the ground electrode are separated by a dielectric separator wherein the ground electrode and the dielectric separator constitute an adjustable probe tip, and the blast probe further comprises an adjustment unit coupled to the adjustable probe tip and configured to extend and retract the blast probe tip relative to the end of the high voltage electrode. The system further comprises a power supply for providing electrical energy to the system. The system further comprises a switch, an inductor, an electrical storage unit and a voltage protection device each coupled to the blast probe and the power supply via a transmission cable. In some embodiments, the electrical storage unit is a capacitor bank. In some embodiments, the switch is selected from a spark gap, an ignitron, or a solid state switch. The power supply charges the capacitor bank with the electrical energy such that when the switch is activated the capacitor bank transmits the electrical energy to the blast probe. In some embodiments, the high voltage electrode and the ground electrode are separated by a first and a second dielectric separator, wherein the high voltage electrode and the second dielectric separator constitute an adjustable probe tip. The first and second dielectric separators comprise different materials such that the second dielectric is tougher than the first dielectric. The second dielectric surrounds the high voltage electrode in a conic or parabolic formation such that the adjustable probe tip is prevented from bending. In some embodiments, the thixotropic fluid comprises a water suspension of cornstarch. In some embodiments, the thixotropic fluid comprises metal particles. In some embodiments, the thixotropic fluid comprises a combustible liquid.

[0007] Another aspect of the present application relates to a blasting system. The blasting system comprises a solid object having a borehole, a blast probe comprising a high voltage electrode and a ground electrode separated by a dielectric separator, wherein the high voltage electrode and the dielectric separator constitute an adjustable probe tip and an adjustment unit coupled to the adjustable probe tip, wherein the adjustment unit is configured to selectively extend or retract the adjustable probe tip relative to the ground electrode and a blasting media, wherein at least a portion of the high voltage electrode and the ground electrode are submerged in the blast media. In some embodiments, the blast media is a thixotropic fluid. In some embodiments, the thixotropic fluid is a water suspension of cornstarch. In some embodiments, the thixotropic fluid comprises metal particles. In some embodiments, the thixotropic fluid comprises a combustible liquid. Alternatively, the blast media is an electro-rheological fluid. Alternatively, the blast media is a solid. In some embodiments, dielectric separator comprises a first dielectric material and a second dielectric material, wherein the second dielectric material surrounds the high voltage electrode in a conic or parabolic formation such that the adjustable probe tip is prevented from bending. The second dielectric material is tougher than the first dielectric material. The system further

comprises a power supply for providing electrical energy to the system. The system further comprises a switch, an inductor, an electrical storage unit and a voltage protection device each coupled to the blast probe and the power supply via a transmission cable. In some embodiments, the electrical storage unit is a capacitor bank. In some embodiments, the switch is selected from a spark gap, an ignitron, or a solid state switch. The power supply charges the capacitor bank with the electrical energy such that when the switch is activated the capacitor bank transmits the electrical energy to the blast probe.

**[0008]** In yet another aspect, the present application relates to a blast probe. The blast probe comprises a high voltage electrode and a ground electrode separated by a dielectric separator, wherein the high voltage electrode and the dielectric separator constitute an adjustable probe tip and an adjustment unit coupled to the adjustable probe tip, wherein the adjustment unit is configured to selectively extend or retract the adjustable probe tip relative to the ground electrode. In some embodiments, the dielectric separator comprises a first dielectric material and a second dielectric material, wherein the second dielectric material surrounds the high voltage electrode in a conic or parabolic formation such that the adjustable probe tip is prevented from bending. The second dielectric material is tougher than the first dielectric material.

**[0009]** Another aspect of the present application relates to a method of breaking a solid with a blast probe comprising a high voltage electrode and a ground electrode separated by a dielectric separator, wherein the high voltage electrode and the dielectric separator constitute an adjustable probe tip and an adjustment unit coupled to the adjustable probe tip, wherein the adjustment unit is configured to selectively extend or retract the adjustable probe tip relative to the ground electrode. The method comprises adjusting the position of the adjustable probe tip relative to the ground electrode, inserting the blast probe into a borehole within the solid thereby submerging at least a portion of the ground electrode and high voltage electrode in a blasting media, charging an electrical storage unit coupled to the blast probe with electrical energy and transmitting the electrical energy to blast probe such that the electrical energy causes a plasma stream to form between the high voltage electrode and the ground electrode through the blast media. In some embodiments, the dielectric separator comprises a first dielectric material and a second dielectric material, wherein the second dielectric material surrounds the high voltage electrode in a conic or parabolic formation such that the adjustable probe tip is prevented from bending. The second dielectric material is tougher than the first dielectric material. In some embodiments, the blast media is a thixotropic fluid. In some embodiments, the thixotropic fluid is a water suspension of cornstarch. In some embodiments, the thixotropic fluid comprises metal particles. In some embodiments, the thixotropic fluid comprises a combustible liquid. Alternatively, the blast media is an electro-rheological fluid. Alternatively, the blast media is a solid.

**[0010]** In another aspect, the present application relates to a method of breaking a solid. The method comprises inserting a blast probe comprising a high voltage electrode and a ground electrode into a borehole within the solid thereby submerging at least a portion of the ground electrode and high voltage electrode in a blasting media, charging an electrical storage unit coupled to the blast probe with electrical energy and transmitting the electrical energy to blast probe such that the electrical energy causes a plasma stream to form between

the high voltage electrode and the ground electrode through the blast media, wherein the blast media comprises a thixotropic fluid. In some embodiments, the high voltage electrode and the ground electrode are separated by a dielectric separator wherein the high voltage electrode and the dielectric separator constitute an adjustable probe tip. The blast probe further comprises an adjustment unit coupled to the adjustable probe tip and configured to extend or retract the blast probe tip relative to the end of the ground electrode. Alternatively, the high voltage electrode and the ground electrode are separated by a dielectric separator wherein the ground electrode and the dielectric separator constitute an adjustable probe tip, and the blast probe further comprises an adjustment unit coupled to the adjustable probe tip and configured to extend or retract the blast probe tip relative to the end of the high voltage electrode. In some embodiments, the electrical storage unit comprises a capacitor bank. The charging further comprises a power supply coupled to the blast probe and the capacitor bank via a transmission cable, wherein the electrical energy used to charge the capacitor bank is provided by the power supply. The transmitting further comprises a switch coupled to the blast probe and the capacitor bank via the transmission cable, wherein when the transmitting is effectuated by activating the switch such that the capacitor bank is able to transmit the electrical energy to the blast probe. In some embodiments, the switch is selected from a spark gap, an ignitron, or a solid state switch. In some embodiments, the high voltage electrode and the ground electrode are separated by a first and a second dielectric separator, wherein the high voltage electrode and the second dielectric separator constitute an adjustable probe tip. The first and second dielectric separators comprise different materials such that the second dielectric is tougher than the first dielectric. The second dielectric surrounds the high voltage electrode in a conic or parabolic formation such that the adjustable probe tip is prevented from bending. In some embodiments, the thixotropic fluid comprises a water suspension of cornstarch. In some embodiments, the thixotropic fluid comprises metal particles. In some embodiments, the thixotropic fluid comprises a combustible liquid.

#### BRIEF DESCRIPTION OF THE DRAWINGS

**[0011]** FIG. 1 shows the plasma blasting system in accordance with some embodiments of the Present Application.

**[0012]** FIG. 2A shows a close up view of the blasting probe in accordance with some embodiments of the Present Application.

**[0013]** FIG. 2B shows an axial view of the blasting probe in accordance with some embodiments of the Present Application.

**[0014]** FIG. 3 shows a close up view of the blasting probe comprising two dielectric separators for high energy blasting in accordance with some embodiments of the Present Application.

**[0015]** FIG. 4 shows a flow chart illustrating a method of using the plasma blasting system to break or fracture a solid in accordance with some embodiments of the Present Application.

#### DETAILED DESCRIPTION

**[0016]** FIG. 1 illustrates a plasma blasting system **100** for fracturing a solid **102** in accordance with some embodiments where electrical energy is deposited at a high rate (e.g. a few

microseconds), into a blasting media **104** (e.g. an electrolyte), wherein this fast discharge in the blasting media **104** creates plasma confined in a borehole **122** within the solid **102**. A pressure wave created by the discharge plasma emanates from the blast region thereby fracturing the solid **102**.

[0017] In some embodiments, the plasma blasting system **100** comprises a power supply **106**, an electrical storage unit **108**, a voltage protection device **110**, a high voltage switch **112**, transmission cable **114**, an inductor **116**, a blasting probe **118** and a blasting media **104**. In some embodiments, the plasma blasting system **100** comprises any number of blasting probes and corresponding blasting media. In some embodiments, the inductor **116** is replaced with the inductance of the transmission cable **114**. Alternatively, the inductor **116** is replaced with any suitable inductance means as is well known in the art. The power supply **106** comprises any electrical power supply capable of supplying a sufficient voltage to the electrical storage unit **108**. The electrical storage unit **108** comprises a capacitor bank or any other suitable electrical storage means. The voltage protection device **110** comprises a crowbar circuit, Bernades-Merryman topology, or any other voltage-reversal protection means as is well known in the art. The high voltage switch **112** comprises a spark gap, an ignitron, a solid state switch, or any other switch capable of handling high voltages. In some embodiments, the transmission cable **114** comprises a coaxial cable. Alternatively, the transmission cable **114** comprises any transmission cable capable of adequately transmitting the pulsed electrical power.

[0018] In some embodiments, the power supply **106** couples to the voltage protection device **110** and the electrical storage unit **108** via the transmission cable **114** such that the power supply **106** is able to supply power to the electrical storage unit **108** through the transmission cable **114** and the voltage protection device **110** is able to prevent voltage reversal from harming the system. In some embodiments, the power supply **106**, voltage protection device **110** and electric storage unit **108** also couple to the high voltage switch **112** via the transmission cable **114** such that the switch **112** is able to receive a specified voltage/amperage from the electric storage unit **108**. The switch **112** then couples to the inductor **116** which couples to the blasting probe **118** again via the transmission cable **114** such that the switch **112** is able to selectively allow the specified voltage/amperage received from the electric storage unit **108** to be transmitted through the inductor **116** to the blasting probe **118**.

[0019] As shown in FIG. 2A, the blasting probe **118** comprises an adjustment unit **120**, one or more ground electrodes **124**, one or more high voltage electrodes **126** and a dielectric separator **128**, wherein the end of the high voltage electrode **126** and the dielectric separator **128** constitute an adjustable blasting probe tip **130**. The adjustable blasting probe tip **130** is reusable. Specifically, the adjustable blasting probe tip **130** comprises a material and is configured in a geometry such that the force from the blasts will not deform or otherwise harm the tip **130**. Alternatively, any number of dielectric separators comprising any number and amount of different dielectric materials are able to be utilized to separate the ground electrode **124** from the high voltage electrode **126**. In some embodiments, as shown in FIG. 2B, the high voltage electrode **126** is encircled by the hollow ground electrode **124**. Furthermore, in those embodiments the dielectric separator **128** also encircles the high voltage electrode **126** and is used as a buffer between the hollow ground electrode **124** and the

high voltage electrode **126** such that the three **124**, **126**, **128** share an axis and there is no empty space between the high voltage and ground electrodes **124**, **126**. Alternatively, any other configuration of one or more ground electrodes **124**, high voltage electrodes **126** and dielectric separators **128** are able to be used wherein the dielectric separator **128** is positioned between the one or more ground electrodes **124** and the high voltage electrode **126**. For example, the configuration shown in FIG. 2B could be switched such that the ground electrode was encircled by the high voltage electrode with the dielectric separator again sandwiched in between, wherein the end of the ground electrode and the dielectric separator would then comprise the adjustable probe tip.

[0020] The adjustment unit **120** comprises any suitable probe tip adjustment means as are well known in the art. Further, the adjustment unit **120** couples to the adjustable tip **130** such that the adjustment unit **120** is able to selectively adjust/move the adjustable tip **130** axially away from or towards the end of the ground electrode **124**, thereby adjusting the electrode gap **132**. In some embodiments, the adjustment unit **120** adjusts/moves the adjustable tip **130** automatically. The term "electrode gap" is defined as the distance between the high voltage and ground electrode **126**, **124** through the blasting media **104**. Thus, by moving the adjustable tip **130** axially in or out in relation to the end of the ground electrode **124**, the adjustment unit **120** is able to adjust the resistance and/or power of the blasting probe **118**. Specifically, in an electrical circuit, the power is directly proportional to the resistance. Therefore, if the resistance is increased or decreased, the power is correspondingly varied. As a result, because a change in the distance separating the electrodes **124**, **126** in the blasting probe **118** determines the resistance of the blasting probe **118** through the blasting media **104** when the plasma blasting system **100** is fired, this adjustment of the electrode gap **132** is able to be used to vary the electrical power deposited into the solid **102** to be broken or fractured. Accordingly, by allowing more refined control over the electrode gap **132** via the adjustable tip **130**, better control over the blasting and breakage yield is able to be obtained.

[0021] Another embodiment, as shown in FIG. 3, is substantially similar to the embodiment shown in FIG. 2A except for the differences described herein. As shown in FIG. 3, the blasting probe **118** comprises an adjustment unit (not shown), a ground electrode **324**, a high voltage electrode **326**, and two different types of dielectric separators, a first dielectric separator **328A** and a second dielectric separator **328B**. Further, in this embodiment, the adjustable blasting probe tip **330** comprises the end portion of the high voltage electrode **326** and the second dielectric separator **328B**. The adjustment unit (not shown) is coupled to the high voltage electrode **326** and the second dielectric separator **328B** (via the first dielectric separator **328A**), and adjusts/moves the adjustable probe tip **330** axially away from or towards the end of the ground electrode **324**, thereby adjusting the electrode gap **332**. In some embodiments, the second dielectric separator **328B** is a tougher material than the first dielectric separator **328A** such that the second dielectric separator **328B** better resists structural deformation and is therefore able to better support the adjustable probe tip **330**. Similar to the embodiment in FIG. 2A, the first dielectric **328A** is encircled by the ground electrode **324** and encircles the high voltage electrode **326** such that all three share a common axis. However, unlike FIG. 2A, towards the end of the high voltage electrode **326**, the first

dielectric separator **328A** is supplanted by a wider second dielectric separator **328B** which surrounds the high voltage electrode **326** and forms a conic or parabolic support configuration as illustrated in the FIG. **3**. The conic or parabolic support configuration is designed to add further support to the adjustable probe tip **330**. Alternatively, any other support configuration could be used to support the adjustable probe tip. Alternatively, the adjustable probe tip **330** is configured to be resistant to deformation. In some embodiments, the second dielectric separator comprises a polycarbonate tip. Alternatively, any other dielectric material is able to be used. In some embodiments, only one dielectric separator is able to be used wherein the single dielectric separator both surrounds the high voltage electrode throughout the blast probe and forms the conic or parabolic support configuration around the adjustable probe tip. In particular, the embodiment shown in FIG. **3** is well suited for higher power blasting, wherein the adjustable blast tip tends to bend and ultimately break. Thus, due to the configuration shown in FIG. **3**, the adjustable probe tip **330** is able to be reinforced with the second dielectric material **328B** in that the second dielectric material **328B** is positioned in a conic or parabolic geometry around the adjustable tip such that the adjustable probe tip **330** is protected from bending due to the blast.

**[0022]** The blasting media **104**, as shown in FIGS. **1** and **2**, comprises an electrolyte such that the blasting media **104** is able to react with an electrical discharge of the blasting probe **118**. Specifically, the electrolyte comprises any combination of a thixotropic fluid, solid or gel, an electro-rheological fluid (ER fluid), solid or gel, or any other non-thixotropic or electro-rheological fluid, solid or gel. In some embodiments, the blasting media **104** is a thixotropic fluid such as a water suspension of cornstarch. Alternatively, the thixotropic fluid comprises cornstarch suspended in a combustible liquid, which are well known in the art, that has a higher energy content than water and thereby more easily reacts with the electrical discharge as described below. In some embodiments, the blasting media **104** is a thixotropic fluid that further comprises metallic powder. This inclusion of metallic powder will propitiate an exothermal reaction to increase the energetic content of the blasting media **104**.

**[0023]** As shown in FIGS. **1** and **2**, the blasting media **104** is positioned within the borehole **122** of the solid **102**, with the adjustable tip **130** and at least a portion of the ground electrode **124** suspended within the blasting media **104** within the solid **102**. Correspondingly, the blasting media **104** is also in contact with the inner wall of the borehole **122** of the solid **102**. The amount of blasting media **104** to be used is dependent on the size of the solid and the size of the blast desired and its calculation is well known in the art.

**[0024]** The term "thixotropy" describes the reversible isothermal gel/solid/gel transformation induced by shearing and subsequent rest. Thixotropy is a sheer-thinning with time factor/phenomenon, also known as positive thixotropy. Several fluid systems display this property, for example, drilling mud, paint, coatings and many others. Predictably, negative thixotropy, also called antithixotropy, is a rheological phenomenon characterized by a flow-induced increase of the viscosity in time, which is observed in many polymer solutions. Thixotropic fluids are able to be either Newtonian (e.g., have a linear thixotropic response) or non-Newtonian (e.g., have a non-linear thixotropic response). A first property of a non-Newtonian time-dependent thixotropic fluid is that such thixotropic fluids are inert (e.g., non-reactive/non-explosive)

such that the fluids are able to be used in space whereas other combustible fluids cannot. A second property of a non-Newtonian time-dependent thixotropic fluid is that it undergoes a decrease in viscosity with time when it is subjected to a constant shearing force. On the other hand, if the shearing force is applied at a very high rate (e.g. in the order of tens of microseconds), the value of the viscosity of the thixotropic fluid tends to increase proportionally to the shearing rate. Therefore, when the thixotropic fluid is subjected to shearing force due to a high pressure (e.g. up to 2.5 GPa) wave within a matter of tens of microseconds, the viscosity of the thixotropic fluid instantly goes very high, making the fluid appear and react more like a solid material. As described in greater detail below, in the present application, this instantaneous high viscosity of a thixotropic fluid is advantageously used to seal the cavity where the plasma blasting probe **118** is inserted; and thus increasing the blasting pressure making the whole system more efficient.

**[0025]** A similar effect is found with semi-conducting fluids having electro-rheological properties. These ER fluids become substantially more viscous (e.g., so as to react like a solid) when subjected to a high electrical field. Indeed, these ER fluids have the feature of being able to change phase between a liquid and a solid-like gel. Specifically, normally, an ER fluid has its particles suspended in a random fashion. However, when an electric field is applied across the ER fluid, the semi-conducting particles are electrically polarized and form chains. As a result, ER fluids' viscosity are able to be manipulated through use of an electric field in a similar manner to thixotropic fluids and shear forces as described above. Again, similar to above, this instantaneous high viscosity of an ER fluid when subjected to a high electrical field is able to be advantageously used to seal the cavity where the plasma blasting probe **118** is inserted as further described below.

**[0026]** The method and operation **400** of the plasma blasting system **100** will now be discussed in conjunction with a flow chart illustrated in FIG. **4**. In operation, as shown in FIGS. **1** and **2**, the adjustable tip **130** is axially extended or retracted by the adjustment unit **120** thereby adjusting the electrode gap **132** based on the size of the solid **102** to be broken and/or the blast energy desired at the step **402**. The blast probe **118** is then inserted into the borehole **122** of the solid such that at least a portion of the ground and high voltage electrodes **124**, **126** of the plasma blasting probe **118** are submerged or put in contact with the blasting media **104** which is in direct contact with the solid **102** to be fractured or broken at the step **404**. Alternatively, the electrode gap **132** is able to be adjusted after insertion of the blasting probe **118** into the borehole **122**. The electrical storage unit **108** is then charged by the power supply **106** at a relatively low rate (e.g., a few seconds) at the step **406**. The switch **112** is then activated causing the energy stored in the electrical storage unit **108** to discharge at a very high rate (e.g. tens of microseconds) forming a pulse of electrical energy (e.g. tens of thousands of Amperes) that is transmitted via the transmission cable **114** to the plasma blasting probe **118** to the ground and high voltage electrodes **124**, **126** causing a plasma stream to form across the electrode gap **132** through the blast media **104** between the high voltage electrode **126** and the ground electrode **124** at the step **408**.

**[0027]** During the first microseconds of the electrical breakdown, the blasting media **104** is subjected to a sudden increase in temperature (e.g. about 3000 to 4000° C.) due to a plasma channel formed between the electrodes **124**, **126**,

which is confined in the borehole **122** and not able to dissipate. The heat generated vaporizes or reacts with part of the blasting media **104**, depending on if the blasting media **104** comprises a liquid or a solid respectively, creating a steep pressure rise confined in the borehole **122**. Because the discharge is very brief, a blast wave comprising a layer of compressed water vapor (or other vaporized blasting media **104**) is formed in front of the vapor containing most of the energy from the discharge. It is this blast wave that then applies force to the inner walls of the borehole **122** and ultimately breaks or fractures the solid **102**. Specifically, when the pressure expressed by the wave front (which is able to reach up to 2.5 GPa), exceeds the tensile strength of the solid **102**, fracture is expected. Thus, the blasting ability depends on the tensile strength of the solid **102** where the plasma blasting probe **118** is placed, and on the intensity of the pressure formed. The plasma blasting system **100** described herein is able to provide pressures well above the tensile strengths of common rocks (e.g. granite=10-20 MPa, tuff=1-4 MPa, and concrete=7 MPa). Thus, the major cause of the fracturing or breaking of the solid **102** is the impact of this compressed water vapor wave front which is comparable to one resulting from a chemical explosive (e.g., dynamite).

**[0028]** As the reaction continues, the blast wave begins propagating outward toward regions with lower atmospheric pressure. As the wave propagates, the pressure of the blast wave front falls with increasing distance. This finally leads to cooling of the gasses and a reversal of flow as a low-pressure region is created behind the wave front, resulting in equilibrium.

**[0029]** If the blasting media **104** comprises a thixotropic fluid as discussed above, when the pulsed discharge vaporizes part of the fluid, the other part rheologically reacts by instantaneously increasing in viscosity, due to being subjected to the force of the vaporized wave front, such that outer part of the fluid acts solid like. This now high viscosity thixotropic fluid thereby seals the borehole **122** where the blasting probe **118** is inserted. Simultaneously, when the plasma blasting system **100** is discharged, and cracks or fractures begin to form in the solid **102**, this newly high viscosity thixotropic fluid temporarily seals them thereby allowing for a longer time of confinement of the plasma. Thus, the vapors are prevented from escaping before building up a blast wave with sufficient pressure. This increase in pressure makes the blasting process **400** described herein more efficient, resulting in a more dramatic breakage effect on the solid **102** using the same or less energy compared to traditional plasma blasting techniques when water or other non-thixotropic media are used.

**[0030]** Similarly, if the blasting media **104** comprises a ER fluid as discussed above, when the pulsed discharge vaporizes part of the fluid, a strong electrical field is formed instantaneously increasing the non-vaporized fluid in viscosity such that it acts solid like. Similar to above, this now high viscosity ER fluid thereby seals the borehole **122** where the blasting probe **118** is inserted. Simultaneously, when the plasma blasting system **100** is discharged, and cracks or fractures begin to form in the solid **102**, this newly high viscosity ER fluid temporarily seals them thereby allowing for a longer time of confinement of the plasma. Thus, again the vapors are prevented from escaping before building up a blast wave with sufficient pressure.

**[0031]** During testing, the blast probe of the blasting system described herein was inserted into solids comprising either

concrete or granite with cast or drilled boreholes having one inch diameters. A capacitor bank system was used for the electrical storage unit and was charged at a low current and then discharged at a high current via the high voltage switch **112**. Peak power achieved was measured in the megawatts. Pulse rise times were around 10-20  $\mu$ sec and pulse lengths were on the order of 50-100  $\mu$ sec. The system was able to produce pressures of up to 2.5 GPa and break concrete and granite blocks with masses of more than 850 kg.

**[0032]** The method of and apparatus for plasma blasting described herein has numerous advantages. Specifically, by adjusting the blasting probe's tip and thereby the electrode gap, the plasma blasting system is able to provide better control over the power deposited into the specimen to be broken. Consequently, the power used is able to be adjusted according to the size and tensile strength of the solid to be broken instead of using the same amount of power regardless of the solid to be broken. Furthermore, the system efficiency is also increased by using a thixotropic or ER blasting media in the plasma blasting system. Specifically, the thixotropic or ER properties of the blasting media maximize the amount of force applied to the solid relative to the energy input into the system by not allowing the energy to easily escape the borehole as described above. Moreover, because the thixotropic or ER blasting media is inert, it is safer than the use of combustible chemicals. As a result, the plasma blasting system is more efficient in terms of energy, safer in terms of its inert qualities, and requires smaller components thereby dramatically decreasing the cost of operation.

**[0033]** Accordingly, for the mining and civil construction industries this will represent more volume of rock breakage per blast at lower cost with better control. For the public works construction around populated areas this represents less vibration, reduced noise and little to no flying rock produced. For the space exploration industry where chemical explosives are a big concern, the use of this inert blasting media is an excellent alternative. Overall, the method of and apparatus for plasma blasting described herein provides an effective reduction in cost per blast and a higher volume breakage yield of a solid substance while being safe, environmentally friendly and providing better control.

**[0034]** The present invention has been described in terms of specific embodiments incorporating details to facilitate the understanding of principles of construction and operation of the invention. Such reference herein to specific embodiments and details thereof is not intended to limit the scope of the claims appended hereto. It will be readily apparent to one skilled in the art that other various modifications may be made in the embodiment chosen for illustration without departing from the spirit and scope of the invention as defined by the claims.

What is claimed is:

1. A blasting system comprising:

- a. a solid object having a borehole;
- b. a blast probe having a high voltage electrode and a ground electrode, wherein the blast probe is positioned within the borehole; and
- c. a blast media comprising a thixotropic fluid, wherein at least a portion of the high voltage electrode and the ground electrode are submerged in the thixotropic fluid.

2. The blasting system of claim 1, wherein the high voltage electrode and the ground electrode are separated by a dielectric separator wherein the high voltage electrode and the dielectric separator constitute an adjustable probe tip.

3. The blasting system of claim 2, wherein the blast probe further comprises an adjustment unit coupled to the adjustable probe tip and configured to extend or retract the blast probe tip relative to the end of the ground electrode.

4. The blasting system of claim 1, wherein the high voltage electrode and the ground electrode are separated by a dielectric separator wherein the ground electrode and the dielectric separator constitute an adjustable probe tip.

5. The blasting system of claim 4, wherein the blast probe further comprises an adjustment unit coupled to the adjustable probe tip and configured to extend or retract the blast probe tip relative to the end of the high voltage electrode.

6. The blasting system of claim 1, further comprising a power supply for providing electrical energy to the system.

7. The blasting system of claim 6, further comprising a switch, an inductor, an electrical storage unit and a voltage protection device each coupled to the blast probe and the power supply via a transmission cable.

8. The blasting system of claim 7, wherein the electrical storage unit is a capacitor bank.

9. The blasting system of claim 8, wherein the switch is selected from a spark gap, an ignitron, or a solid state switch.

10. The blasting system of claim 9, wherein the power supply charges the capacitor bank with the electrical energy such that when the switch is activated the capacitor bank transmits the electrical energy to the blast probe.

11. The blasting system of claim 1, wherein the high voltage electrode and the ground electrode are separated by a first and a second dielectric separator, wherein the high voltage electrode and the second dielectric separator constitute an adjustable probe tip.

12. The blasting system of claim 11, wherein the first and second dielectric separators comprise different materials such that the second dielectric is tougher than the first dielectric.

13. The blasting system of claim 12, wherein the second dielectric surrounds the high voltage electrode in a conic or parabolic formation such that the adjustable probe tip is prevented from bending.

14. The blasting system of claim 1, wherein the thixotropic fluid comprises a water suspension of cornstarch.

15. The blasting system of claim 1, wherein the thixotropic fluid comprises metal particles.

16. The blasting system of claim 1, wherein the thixotropic fluid comprises a combustible liquid.

17. A blasting system comprising:

a. a solid object having a borehole;

b. a blast probe comprising:

i. a high voltage electrode and a ground electrode separated by a dielectric separator, wherein the high voltage electrode and the dielectric separator constitute an adjustable probe tip; and

ii. an adjustment unit coupled to the adjustable probe tip, wherein the adjustment unit is configured to selectively extend or retract the adjustable probe tip relative to the ground electrode; and

c. a blasting media, wherein at least a portion of the high voltage electrode and the ground electrode are submerged in the blasting media.

18. The blasting system of claim 17, wherein the blast media is a thixotropic fluid.

19. The blasting system of claim 18, wherein the thixotropic fluid is a water suspension of cornstarch.

20. The blasting system of claim 18, wherein the thixotropic fluid comprises metal particles.

21. The blasting system of claim 18, wherein the thixotropic fluid comprises a combustible liquid.

22. The blasting system of claim 17, wherein the blast media is an electro-rheological fluid.

23. The blasting system of claim 17, wherein the blast media is a solid.

24. The blasting system of claim 17, wherein the dielectric separator comprises a first dielectric material and a second dielectric material, wherein the second dielectric material surrounds the high voltage electrode in a conic or parabolic formation such that the adjustable probe tip is prevented from bending.

25. The blasting system of claim 24, wherein the second dielectric material is tougher than the first dielectric material.

26. The blasting system of claim 17, further comprising a power supply for providing electrical energy to the system.

27. The blasting system of claim 26, further comprising a switch, an inductor, an electrical storage unit and a voltage protection device each coupled to the blast probe and the power supply via a transmission cable.

28. The blasting system of claim 27, wherein the electrical storage unit is a capacitor bank.

29. The blasting system of claim 28, wherein the switch is selected from a spark gap, an ignitron, or a solid state switch.

30. The blasting system of claim 29, wherein the power supply charges the capacitor bank with the electrical energy such that when the switch is activated the capacitor bank transmits the electrical energy to the blast probe.

31. A blast probe comprising:

a. a high voltage electrode and a ground electrode separated by a dielectric separator, wherein the high voltage electrode and the dielectric separator constitute an adjustable probe tip; and

b. an adjustment unit coupled to the adjustable probe tip, wherein the adjustment unit is configured to selectively extend or retract the adjustable probe tip relative to the ground electrode.

32. The blast probe of claim 31, wherein the dielectric separator comprises a first dielectric material and a second dielectric material, wherein the second dielectric material surrounds the high voltage electrode in a conic or parabolic formation such that the adjustable probe tip is prevented from bending.

33. The blast probe of claim 32, wherein the second dielectric material is tougher than the first dielectric material.

34. A method of breaking a solid with a blast probe comprising a high voltage electrode and a ground electrode separated by a dielectric separator, wherein the high voltage electrode and the dielectric separator constitute an adjustable probe tip and an adjustment unit coupled to the adjustable probe tip, wherein the adjustment unit is configured to selectively extend or retract the adjustable probe tip relative to the ground electrode, the method comprising:

a. adjusting the position of the adjustable probe tip relative to the ground electrode;

b. inserting the blast probe into a borehole within the solid thereby submerging at least a portion of the ground electrode and high voltage electrode in a blasting media;

c. charging an electrical storage unit coupled to the blast probe with electrical energy; and

d. transmitting the electrical energy to blast probe such that the electrical energy causes a plasma stream to form

between the high voltage electrode and the ground electrode through the blast media.

35. The method of claim 34, wherein the dielectric separator comprises a first dielectric material and a second dielectric material, wherein the second dielectric material surrounds the high voltage electrode in a conic or parabolic formation such that the adjustable probe tip is prevented from bending.

36. The method of claim 35, wherein the second dielectric material is tougher than the first dielectric material.

37. The method of claim 34, wherein the blast media is a thixotropic fluid.

38. The method of claim 37, wherein the thixotropic fluid is a water suspension of cornstarch.

39. The method of claim 37, wherein the thixotropic fluid comprises metal particles.

40. The method of claim 37, wherein the thixotropic fluid comprises a combustible liquid.

41. The method of claim 34, wherein the blast media is an electro-rheological fluid.

42. The method of claim 34, wherein the blast media is a solid.

43. A method of breaking a solid comprising:

- a. inserting a blast probe comprising a high voltage electrode and a ground electrode into a borehole within the solid thereby submerging at least a portion of the ground electrode and high voltage electrode in a blasting media;
- b. charging an electrical storage unit coupled to the blast probe with electrical energy; and
- c. transmitting the electrical energy to blast probe such that the electrical energy causes a plasma stream to form between the high voltage electrode and the ground electrode through the blast media;

wherein the blast media comprises a thixotropic fluid.

44. The method of claim 43, wherein the high voltage electrode and the ground electrode are separated by a dielectric separator wherein the high voltage electrode and the dielectric separator constitute an adjustable probe tip.

45. The method of claim 44, wherein the blast probe further comprises an adjustment unit coupled to the adjustable probe tip and configured to extend or retract the blast probe tip relative to the end of the ground electrode.

46. The method of claim 43, wherein the high voltage electrode and the ground electrode are separated by a dielectric separator wherein the ground electrode and the dielectric separator constitute an adjustable probe tip.

47. The method of claim 46, wherein the blast probe further comprises an adjustment unit coupled to the adjustable probe tip and configured to extend or retract the blast probe tip relative to the end of the high voltage electrode.

48. The method of claim 43, wherein the electrical storage unit comprises a capacitor bank.

49. The method of claim 48, wherein the charging further comprises a power supply coupled to the blast probe and the capacitor bank via a transmission cable, wherein the electrical energy used to charge the capacitor bank is provided by the power supply.

50. The method of claim 49, wherein the transmitting further comprises a switch coupled to the blast probe and the capacitor bank via the transmission cable, wherein when the transmitting is effectuated by activating the switch such that the capacitor bank is able to transmit the electrical energy to the blast probe.

51. The method of claim 50, wherein the switch is selected from a spark gap, an ignitron, or a solid state switch.

52. The method of claim 43, wherein the high voltage electrode and the ground electrode are separated by a first and a second dielectric separator, wherein the high voltage electrode and the second dielectric separator constitute an adjustable probe tip.

53. The method of claim 52, wherein the first and second dielectric separators comprise different materials such that the second dielectric is tougher than the first dielectric.

54. The method of claim 53, wherein the second dielectric surrounds the high voltage electrode in a conic or parabolic formation such that the adjustable probe tip is prevented from bending.

55. The method of claim 43, wherein the thixotropic fluid comprises a water suspension of cornstarch.

56. The method of claim 55, wherein the thixotropic fluid comprises metal particles.

57. The method of claim 55 wherein the thixotropic fluid comprises a combustible liquid.

\* \* \* \* \*