

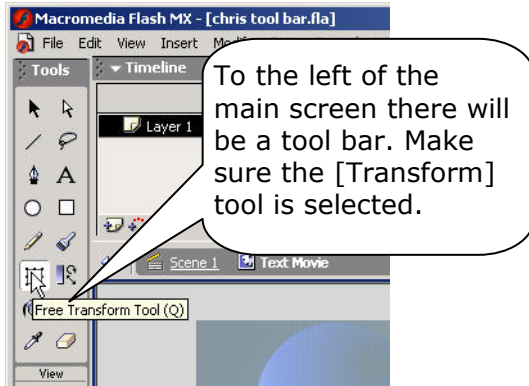

## Step 1

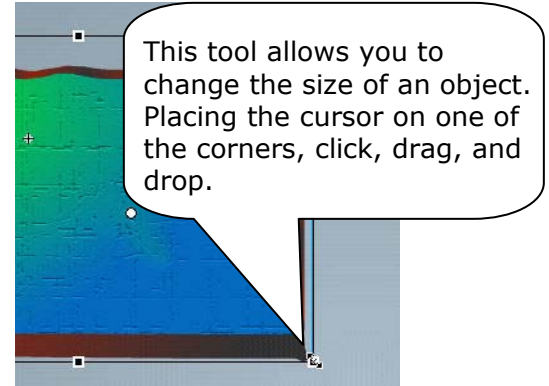

## Step 2



## Step 3

This tool also allows you rotate an object by placing the cursor next to one of the corners. Look for the circular arrow, then drag in the direction you wish to rotate the image.

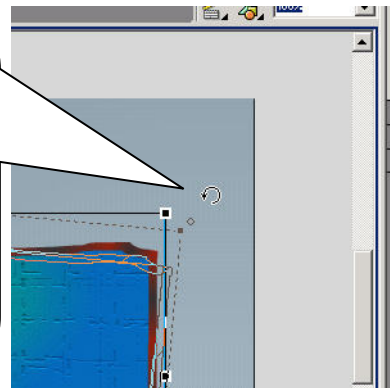

## Step 4

